

# 7116-MWS

# RF/Microwave Switch System

## 1x16 Multiplexer



- **Integrated solution, including controller and RF/microwave switches**
- **Compact RF/microwave switching system only 3U high**
- **Configurable as one 1x16 or five independent 1x4 multiplexers**
- **18GHz bandwidth relays**
- **Real-time status display of all switches**
- **Local and remote control**

### Ordering Information

7116-MWS 16-Channel  
Microwave Switch  
System

Extended warranty, service, and  
calibration contracts are available.

### Accessories Supplied

Instruction manual and power  
line cord

The Model 7116-MWS is a fully assembled 16-Channel RF/Microwave Switch System designed to simplify controlling high frequency switching. It employs the IEEE-488-compatible Model 7001 Switch Mainframe as a switch controller as well as electromechanical coaxial relays with a bandwidth from DC to 18GHz. Applications include production and laboratory testing of a variety of communications devices and systems.

### Simple Setup and Control

All input and output connections are easily accessible from the front panel, so system maintenance and reconfiguration is fast and easy. In addition, the non-volatile memory in the Model 7001 is pre-programmed in a 1x16 multiplexer switching pattern, allowing users to begin operating it immediately.

### High Signal Integrity

All RF/microwave relay interconnections are implemented using low-loss, semi-rigid RF cabling to ensure high signal integrity. Signal paths are of equal length to ensure similar transmission line characteristics and performance in every channel. The relays used provide high isolation to minimize channel crosstalk. The Model 7116-MWS's combination of low insertion loss and high isolation ensures high quality measurement pathways for signal routing and measurement.

### Expandable

The Model 7001 mainframe has a spare card slot available that allows control of up to 40 additional switch channels. More than 30 cards are available to expand the Model 7116-MWS's switching capabilities to include low frequency, general purpose, optical, or additional RF switching.

### Industry-Leading IEEE-488 Controller

The Keithley Model 7001 Switch Mainframe included in the Model 7116-MWS has a distinctive front panel vacuum fluorescent display that provides continuous, real-time information on the status of all switches. Intuitive front panel controls allow the system to be manually operated, speeding and simplifying test verification and troubleshooting. Up to 100 complete switch patterns can be programmed in the Model 7001's non-volatile memory.

### APPLICATIONS

- **Cellular and cordless phones**
- **Specialized mobile radios**
- **Base stations**
- **Specialized antenna systems**
- **RF components, including RFICs**
- **Wireless peripherals, including Bluetooth devices**
- **Broadband wireless transceivers**
- **High speed digital communications, including SONET speeds 3Gbps and 10Gbps**

1.888.KEITHLEY (U.S. only)

[www.keithley.com](http://www.keithley.com)

**KEITHLEY**

A GREATER MEASURE OF CONFIDENCE

Pre-configured RF/microwave switch system

RF/MICROWAVE SWITCHING  
AND MEASUREMENT

# 7116-MWS

# RF/Microwave Switch System

## 1×16 Multiplexer

### Keithley Design Assistance

For applications that require a larger switching system or an unusual switch configuration, Keithley can assemble a customized turnkey signal routing system to meet unique specifications, including operating frequencies up to 40GHz. For example, systems can be assembled with microwave relays, programmable attenuators, couplers, isolators, amplifiers, power dividers/combiners, etc. Keithley also offers high capacity switch controllers that can accommodate up to 400 switches. Contact Keithley's Applications Engineering team for additional information.

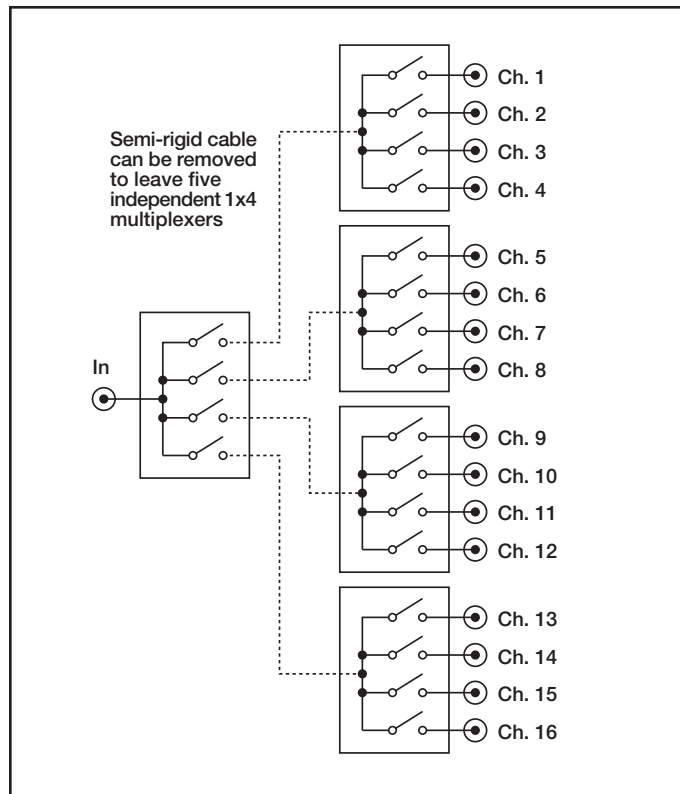

### SYSTEM SPECIFICATIONS

Operating Frequency	DC-3 GHz	3-6 GHz	6-12 GHz	12-18 GHz
Insertion Loss dB, maximum	0.5 (0.2)	0.75 (0.3)	1 (0.4)	1.3 (0.5)
Isolation dB, minimum	80	70	60	60
RF Power W, maximum	30 (34)	20 (34)	15 (34)	10 (34)
VSWR	1.35 (1.2)	1.5 (1.3)	1.7 (1.4)	1.9 (1.5)

Values in parentheses are for individual SP4T switches.

**SWITCH CONFIGURATION:** 16 input coaxial multiplexer. Five independent unterminated SP4T switches when jumpers removed.

**CONNECTOR:** SMA.

**ACTUATING CURRENT:** 140mA per switch contact.

**IMPEDANCE:** 50Ω.

**ACTUATION TIME:** 15ms.

**RF CONTACTS:** Break-before-make, normally open.

**OPERATING LIFE: Cold Switching:** 1,000,000 operations.

**CONFIGURATION:**

**Control:** 7001 mainframe and 7020-MWS.

**Power Supply:** 29V DC, 1.6A switching power supply.

**RF Interconnects:** RG-402 (0.141 in. semi-rigid cable terminated with male SMA connectors).

**Switch:** Normally open, DC-18GHz unterminated SP4T switch.

**System Enclosure:** 5¼ in. full system rack kit.

**EMC:** Conforms to European Union Directive 89/336/EEC.

**SAFETY:** Conforms to European Union Directive 73/23/EEC (meets EN61010-1/IEC 1010).

**POWER:** 90-260V AC, 47-63Hz, 80VA maximum.

**ENVIRONMENT:**

**Operating:** 0°-50°C, up to 35°C at 80% R.H.

**Storage:** -25°C to +65°C.

**DIMENSIONS, WEIGHT:** 133mm high × 482mm wide × 457mm deep (5¼ in × 19 in × 18 in). Net weight 8.1kg (18 lbs).

### ACCESSORIES AVAILABLE

7116-COVER Top Protective Cover

1.888.KEITHLEY (U.S. only)

[www.keithley.com](http://www.keithley.com)

**KEITHLEY**